

Rents Starting From The  
**Low \$30's**  
Fully Serviced

For Lease

**22 Battery St.**

San Francisco, CA 94111

Flexible spaces and layouts  
In the heart of FiDi, near transit

Hans Hansson  
415.517.2589

Frank Vella  
650.464.8062



**STARBOARD CRE**  
LOCAL • INDEPENDENT • ENTREPRENEURIAL

STARBOARDCRE.COM  
49 POWELL STREET, SAN FRANCISCO, CA 94102

## 22 BATTERY ST.

- 22 Battery is located in The Financial District, the largest concentration of corporate headquarters, law firms, insurance companies, real estate firms, banks, and other financial institutions.
- Excellent parking nearby with a variety of garages. Also a short walking distance to Union Square, SoMa, and The Ferry Building.
- Access to public transit is exceptional, as four BART lines stop in the Financial District, and most lines in the city's MUNI light rail and bus systems feed into the downtown core running down Market Street.



---

Space should be delivered as is in good working order, any improvement necessary can be amortized as additional rent.

## SUITE 200

- ± 787 SF
- All open plan Space
- Can maximize number of Workstations
- Right off lobby
- Double Door Identity



## SUITE 202

- ± 1,772 SF
- Open Area
- 3 Private Rooms
- Operable Windows
- Kitchenette
- Market Street Views
- Flooring Option is Tenant's Choice of Building Standard Material



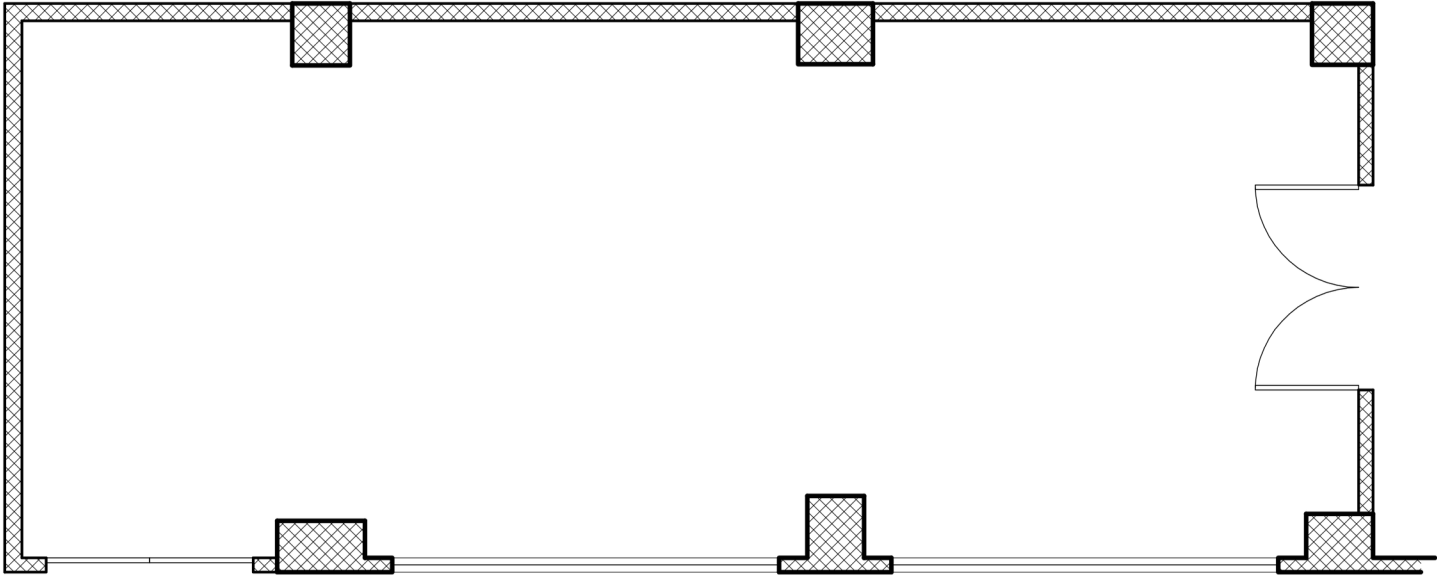

Battery Street

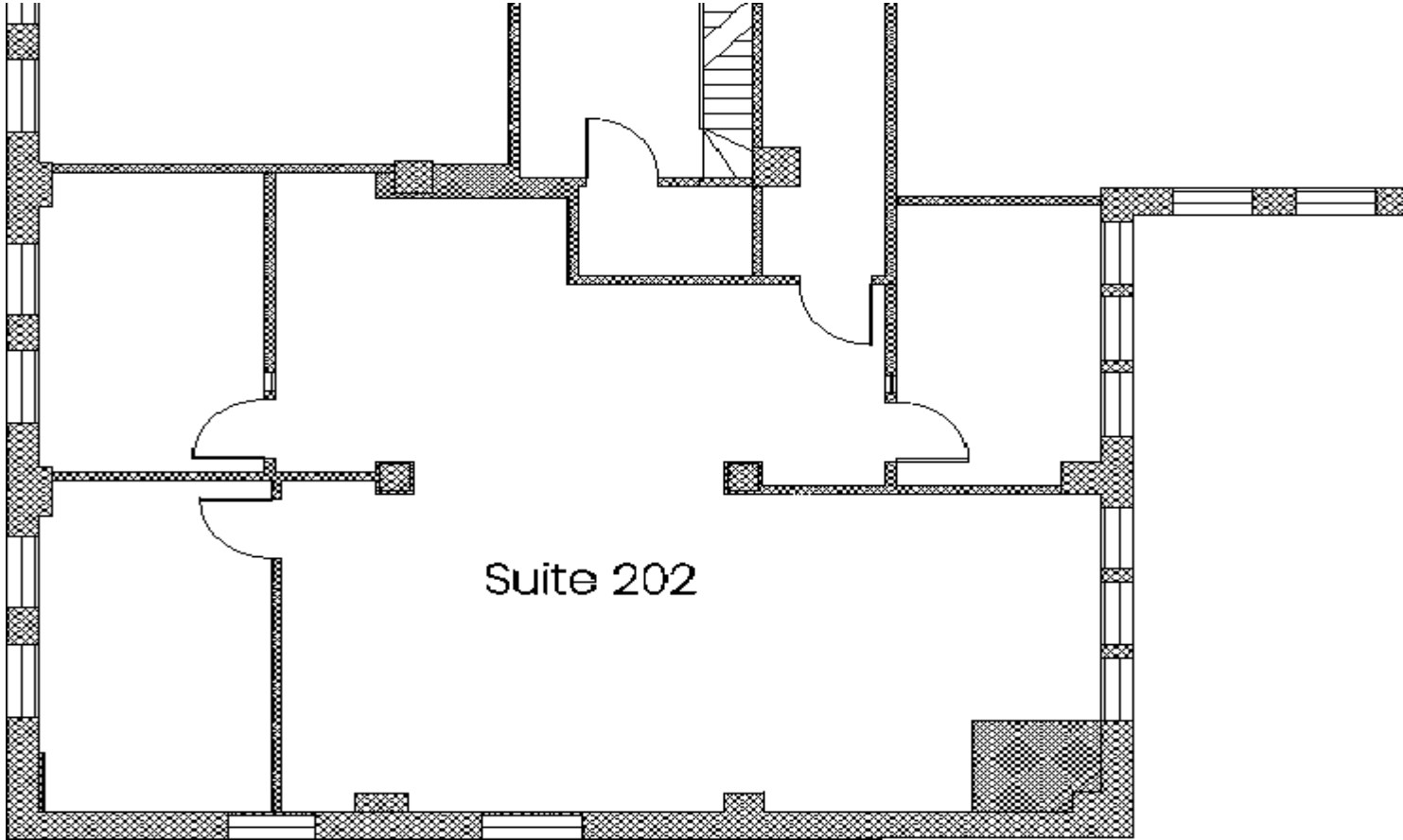

Suite 202

## SUITE 505

- ± 656 SF
- Reception Area
- Two private office and open area
- Include Sink



## SUITE 510

- ± 899 SF
- 3 Large Offices
- New Carpet
- Sink Available
- Waiting Lounge Area



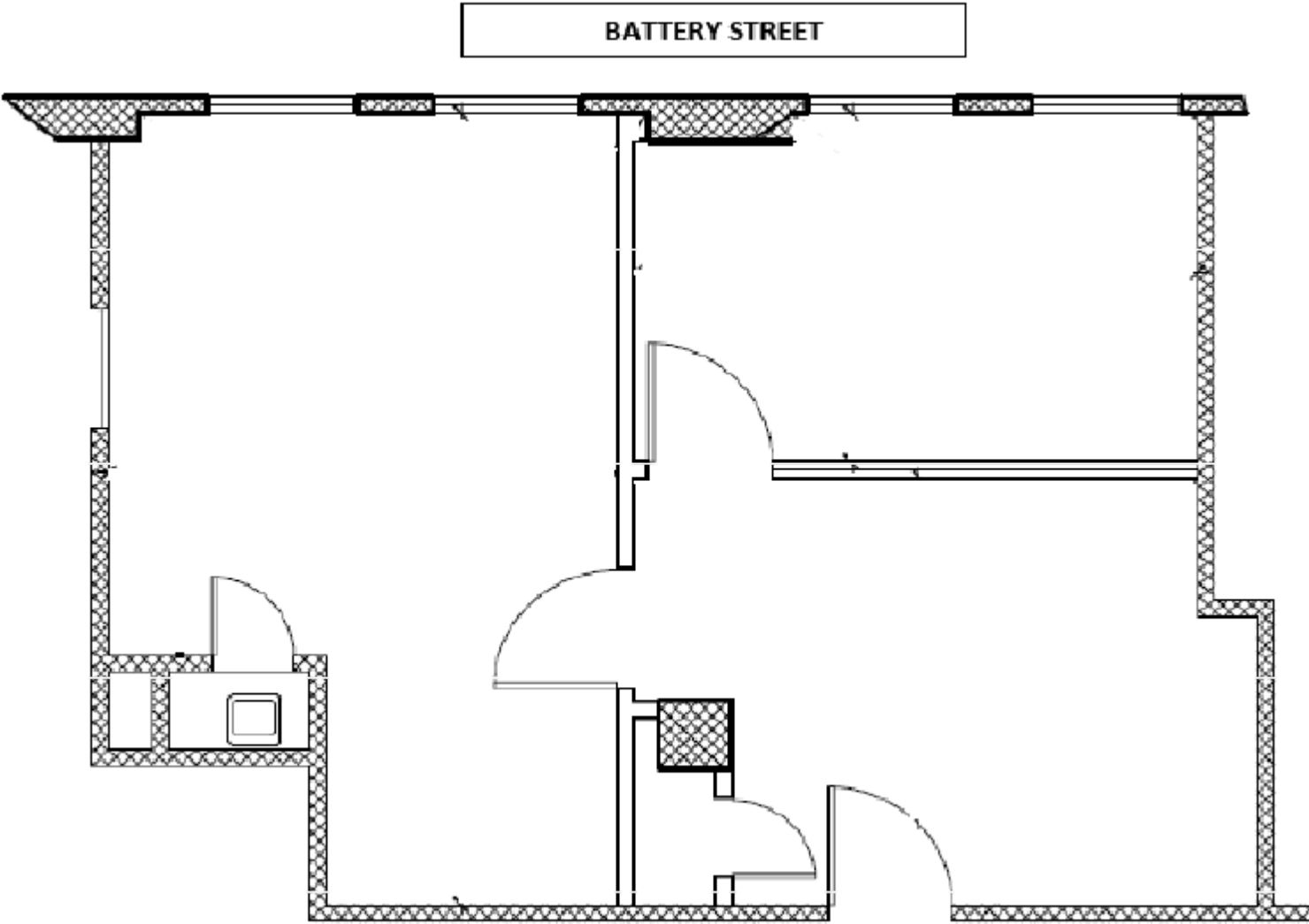

This information has been secured by Starboard CRE from sources believed to be reliable. It is not guaranteed and should be verified before closing any transaction.

# SUITE 510 | FLOORPLAN

For Lease

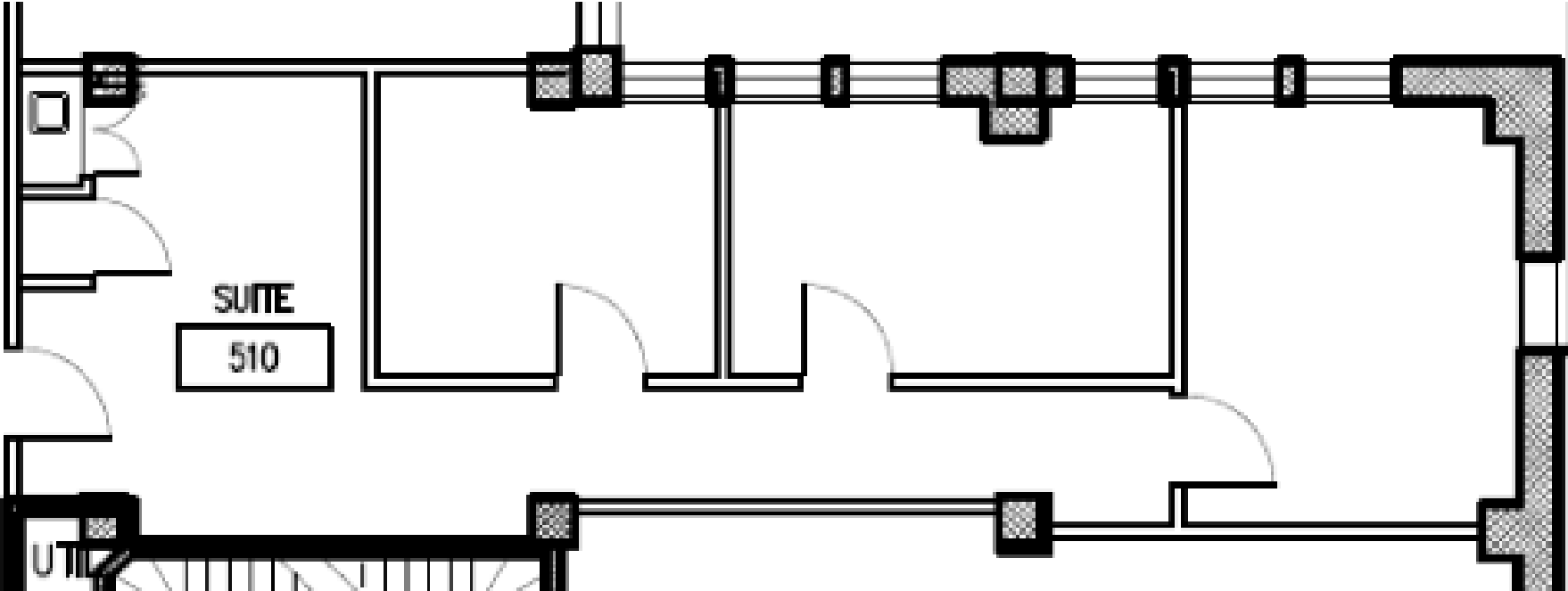

This information has been secured by Starboard CRE from sources believed to be reliable. It is not guaranteed and should be verified before closing any transaction.



## SUITE 610 & 614

- ± 2788 SF
- 1 Conference Room
- 5 Offices
- 1 Kitchen
- Large Open Layout
- Reception Area



# SUITE 610-614 | FLOORPLAN

For Lease

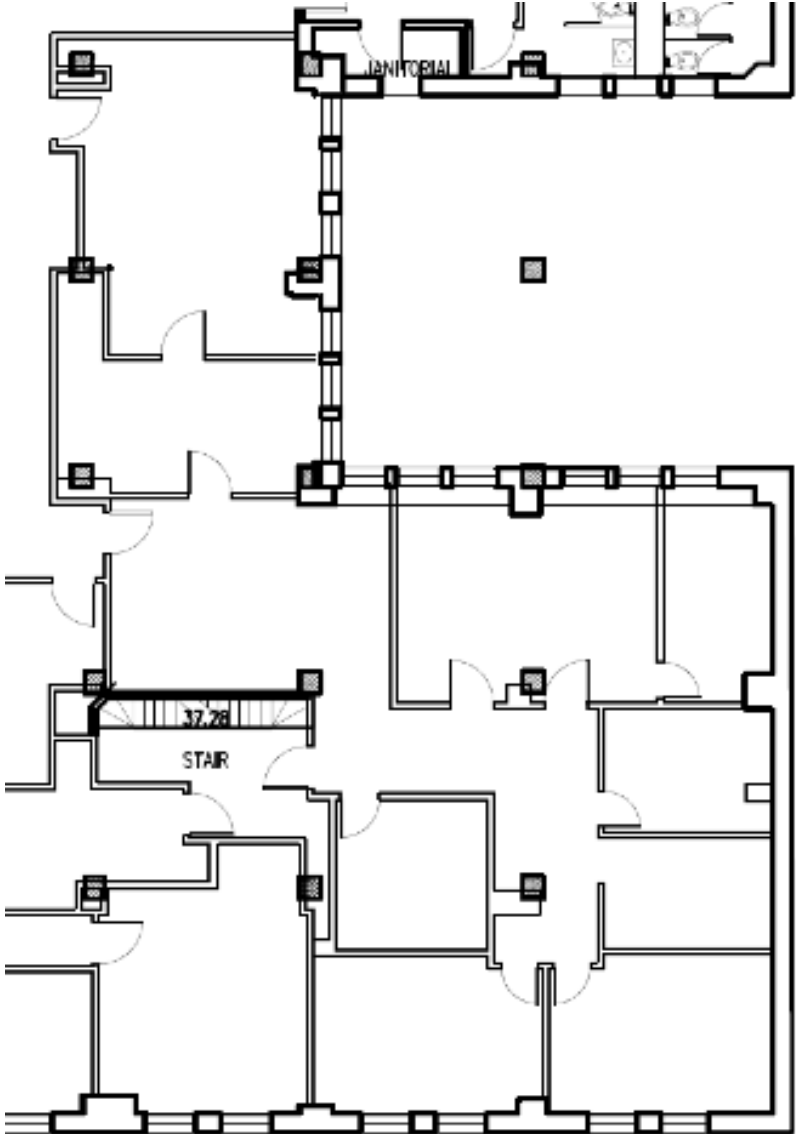

This information has been secured by Starboard CRE from sources believed to be reliable. It is not guaranteed and should be verified before closing any transaction.

## SUITE 701 & 704

- ± 1,470 SF
- 4 Private Rooms
- Lots of Storage
- Build Out Space
- Flooring Option is Tenant's

Choice of Building Standard Material



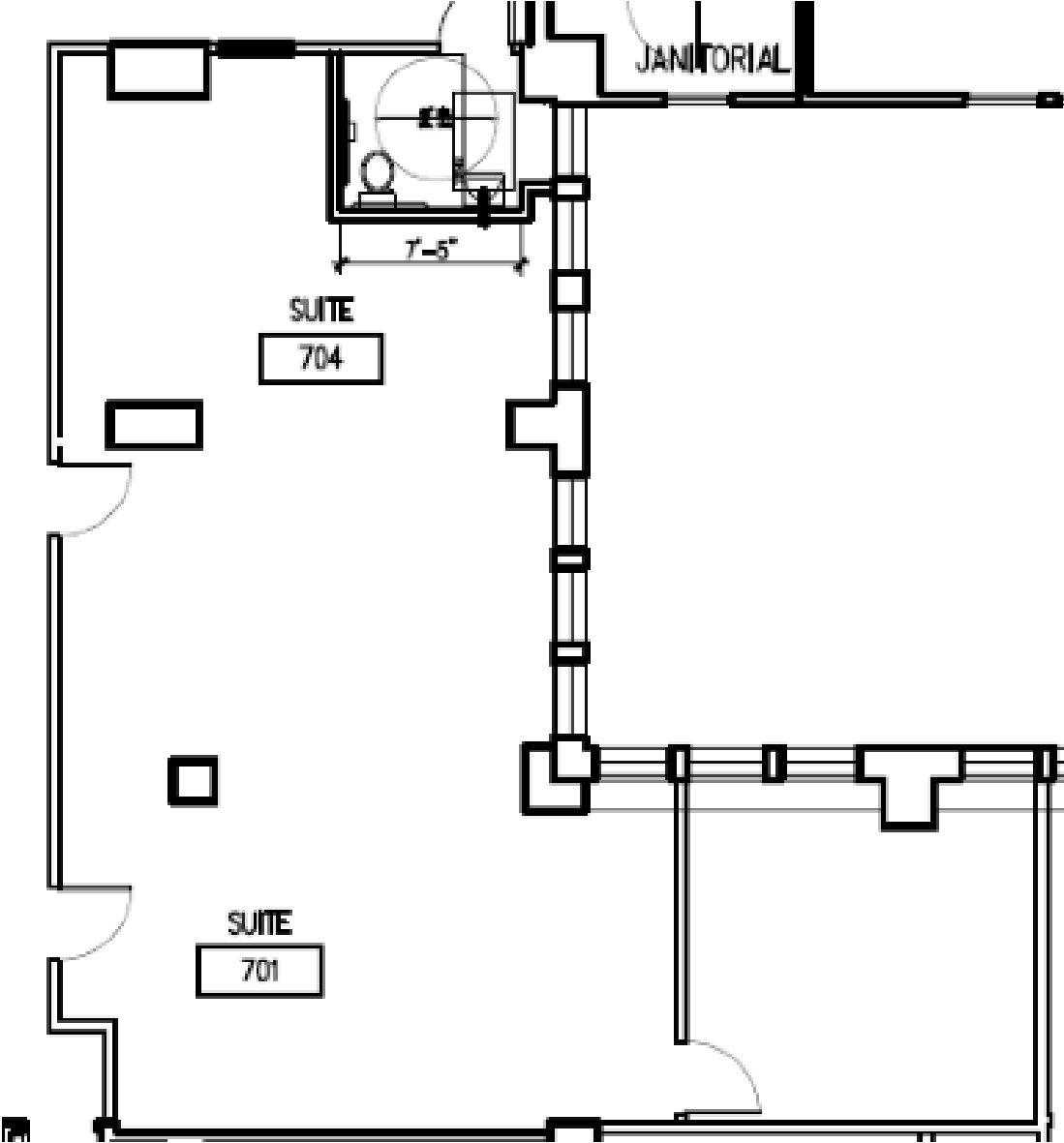

This information has been secured by Starboard CRE from sources believed to be reliable. It is not guaranteed and should be verified before closing any transaction.

## SUITE 806

- ± 1,241 SF
- Large Open Area
- 1 Private Office



## SUITE 810

- ± 1,381 SF
- Reception Area
- 3 Private Office
- Kitchenette



# SUITE 806 & 810 | FLOORPLAN

For Lease

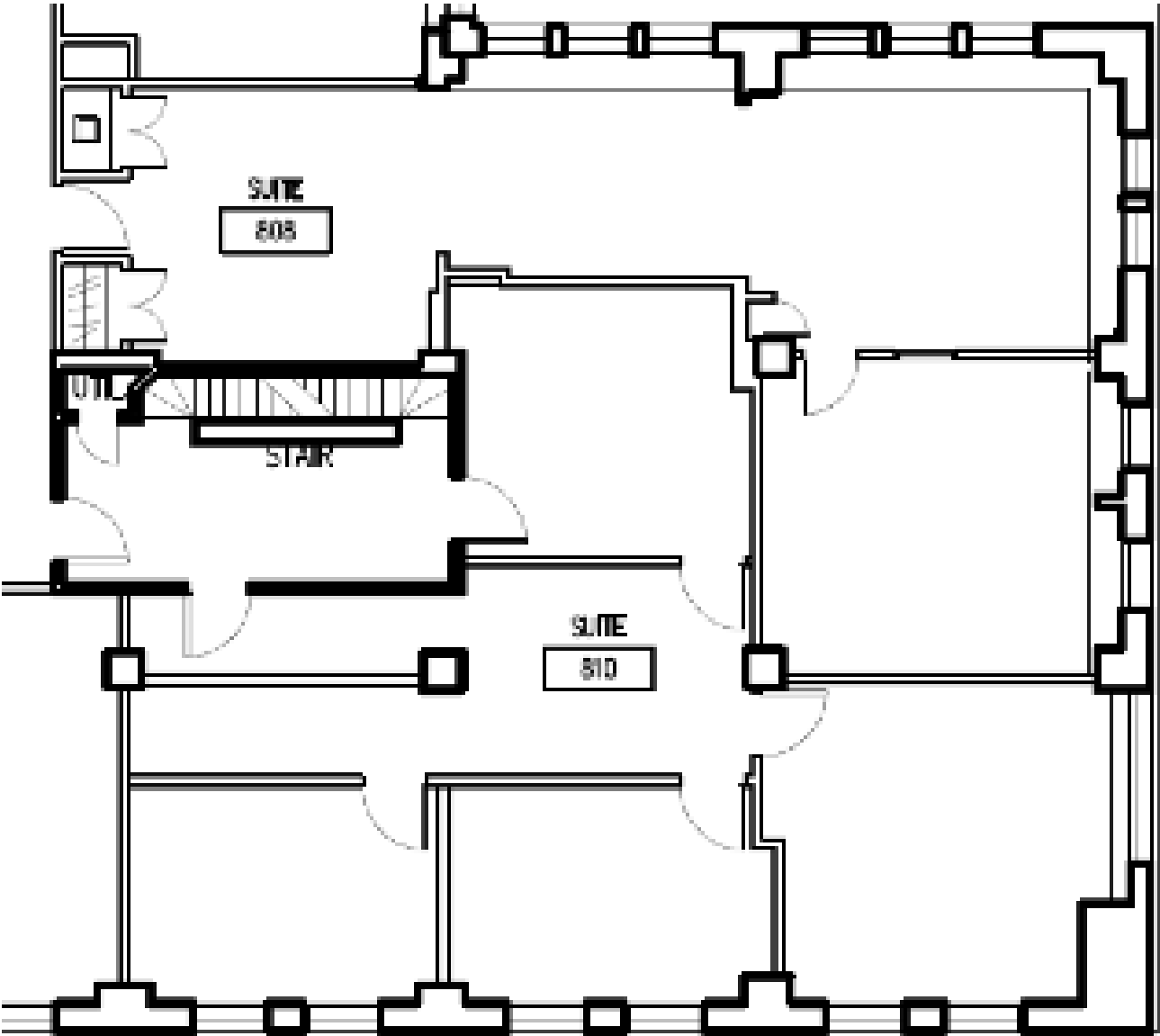

This information has been secured by Starboard CRE from sources believed to be reliable. It is not guaranteed and should be verified before closing any transaction.

## SUITE 900 & 905

- Divisible
- Suite 900/905: ± 2,830 SF
- Reception / seating lounge
- Lots of storage space and cabinets
- Kitchenette
- 2 entries to suites
- Bathroom inside the space



# SUITE 900 | FLOORPLAN

For Lease

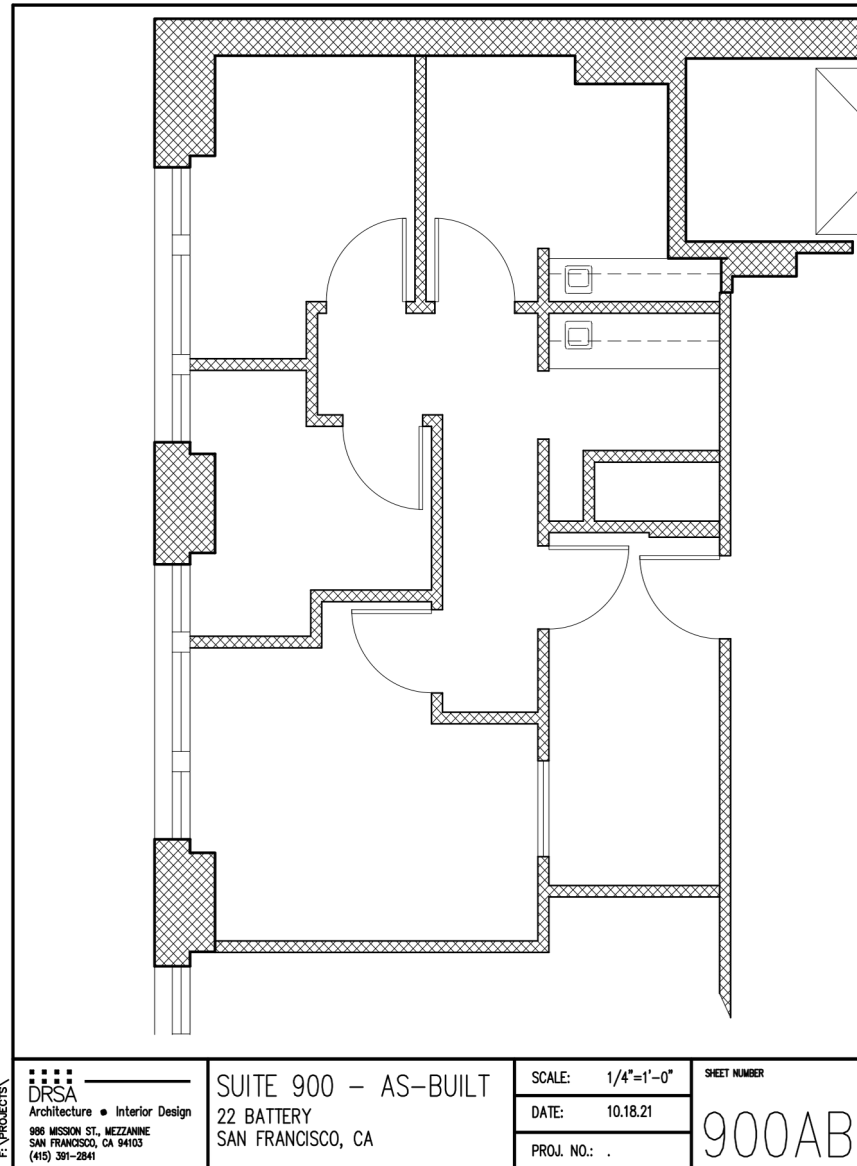

This information has been secured by Starboard CRE from sources believed to be reliable. It is not guaranteed and should be verified before closing any transaction.



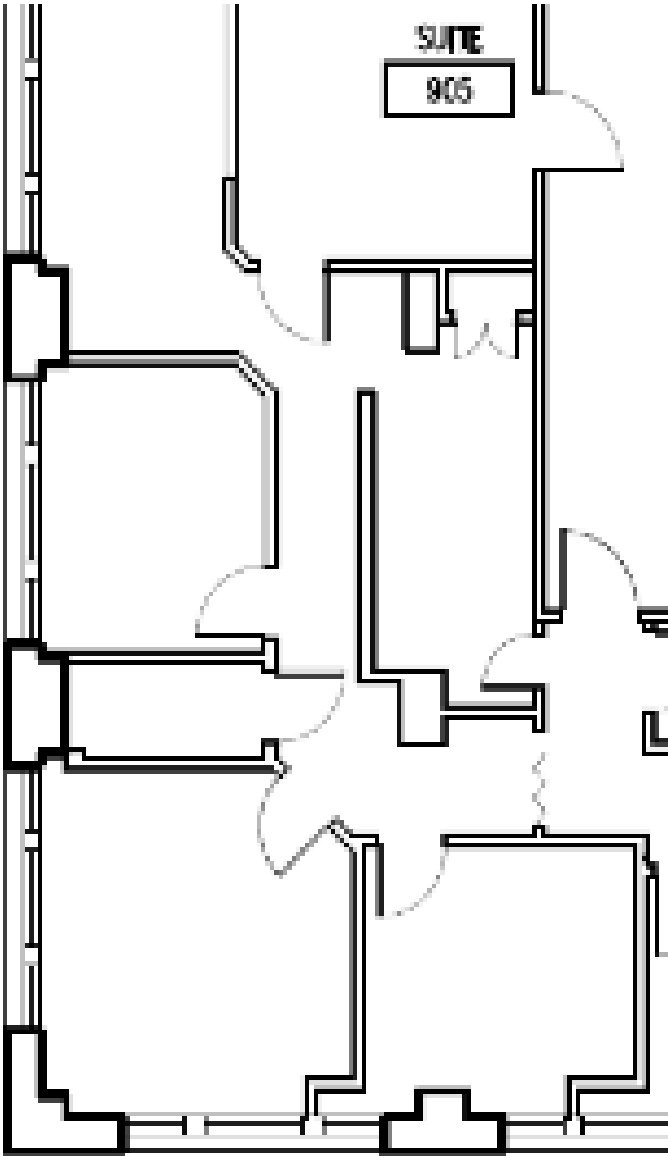

This information has been secured by Starboard CRE from sources believed to be reliable. It is not guaranteed and should be verified before closing any transaction.



## Hans Hansson

President / Broker of Record  
hans@starboardcre.com  
CELL: 650.464.8062  
OFFICE: 415.517.2589  
CA DRE # 00872902

Call

View Profile



## Frank Vella

Broker Associate  
frank@starboardcre.com  
CELL: 650.464.8062  
OFFICE: 415.765.6900  
CA DRE # 01104977

Call

View Profile



**STARBOARD CRE**  
LOCAL • INDEPENDENT • ENTREPRENEURIAL

STARBOARDCRE.COM  
49 POWELL STREET, SAN FRANCISCO, CA 94102



## Unique Vision

We see what others miss

## Local Market Leader

No one knows Northern  
California like we do

## Full-Service Firm

We do it all

---

Locally based, and technology-forward, our brokers are highly qualified experts backed by a full-service, in-house support team who understand the intricacies of San Francisco real estate. Starboard CRE brings decades of brokerage experience representing over 600 million square feet of space with an aggregate lease value of over 10 billion and investments sold over 3 billion.

**CA DRE# 01103056**

